



Halal and gluten-free compatible Eel Kabayaki (Frozen grilled eel)



Live Eel Division, Fuji Bussan Co.

I Product Overview (eel)



Our new product
"Frozen grilled eel"

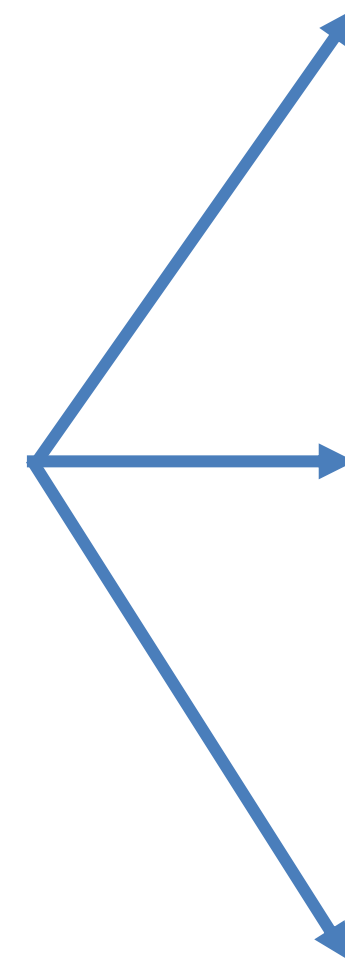

①sauce



②gluten-free



③halal



Characteristics that
set it apart from others



I Product Overview (sauce)

①soy sauce

Tamari soy sauce is used, which accounts for only 1% of the total production of soy sauce.

Tamari soy sauce has a strong flavor because it is made from soybeans only.

The soy sauce is made without wheat and alcohol.

✘Alcohol is not normally used in honjoso shoyu, but many manufacturers add alcohol for preservation purposes. However, many manufacturers add alcohol for preservation purposes.

The limited production of soy sauce makes it a product that other companies cannot imitate.



②oligosaccharide

- Galactooligosaccharide, which is expected to increase the number of bifidobacteria in the intestines and improve constipation when taken in certain amounts on a regular basis, is added.

③sugar

- Sugar beet molasses produced from sugar beet. Rich in oligosaccharides and many minerals

I Product Overview (gluten-free)

【 gluten-free 】

A product that does not contain gluten, a protein found in grains such as wheat, rye, and barley.

Originally, gluten-free products were intended for patients with gluten intolerance, irritable bowel syndrome (IBS), and celiac disease, but since around 2002, the gluten-free market has expanded in the United States, the largest market, to include health-conscious consumers who are not patients.

【 market scale 】

The global gluten-free products market reached a size of US\$17.5 billion in 2021. Currently, the number of patients with celiac disease is also on the rise, and the market is expected to grow at a CAGR of 8.2% from 2022 to 2027, reaching a value of US\$28.3 billion by 2027.

【product】

▪Inspection was conducted at Vision Bio Co. →No gluten detected



I Product Overview (halal)

【halal】

Halal refers to “all wholesome products and activities permitted by Islamic teachings. In the case of food products, it means that the ingredients do not contain alcohol or ingredients derived from pigs, and that the meat is slaughtered according to Islamic methods. In recent years, the term has been used not only to refer to food products, but also to a wide range of other fields, including retail, sales, tourism, hotels, restaurants, logistics, and finance, as well as manufacturing of health foods, cosmetics, household goods, pharmaceuticals, and other products.

【 market scale 】

The global halal food market size reached US\$2,221.3 billion in 2022 and is expected by the IMARC Group to reach US\$4,177.3 billion by 2028, representing a growth rate of 10.8% between 2023 and 2028 (CAGR).

【product】

Acquisition of certification by Japan Halal Certification Promotion Organization (JHCPO) Plans to acquire certification in Indonesia (BPJPH) in the future



II Product image ①Dimensions/Photographs

①size Piece (bag): 130mm × 410mm × 10~20mm (W × D × H) ,

② Packaging Materials PE PA

③ Package method Deep Draw Vacuum Packaging or Skin Pack Packaging



骨側



皮側

II Product image ② Package

① size Case (box): 365mm x 490mm x 230mm (W x D x H)

② display Name of product, ingredients, storage method, content, manufacturer, nutritional information, and expiration date

③ Packing method Individually vacuum-packed and packed with gummed tape

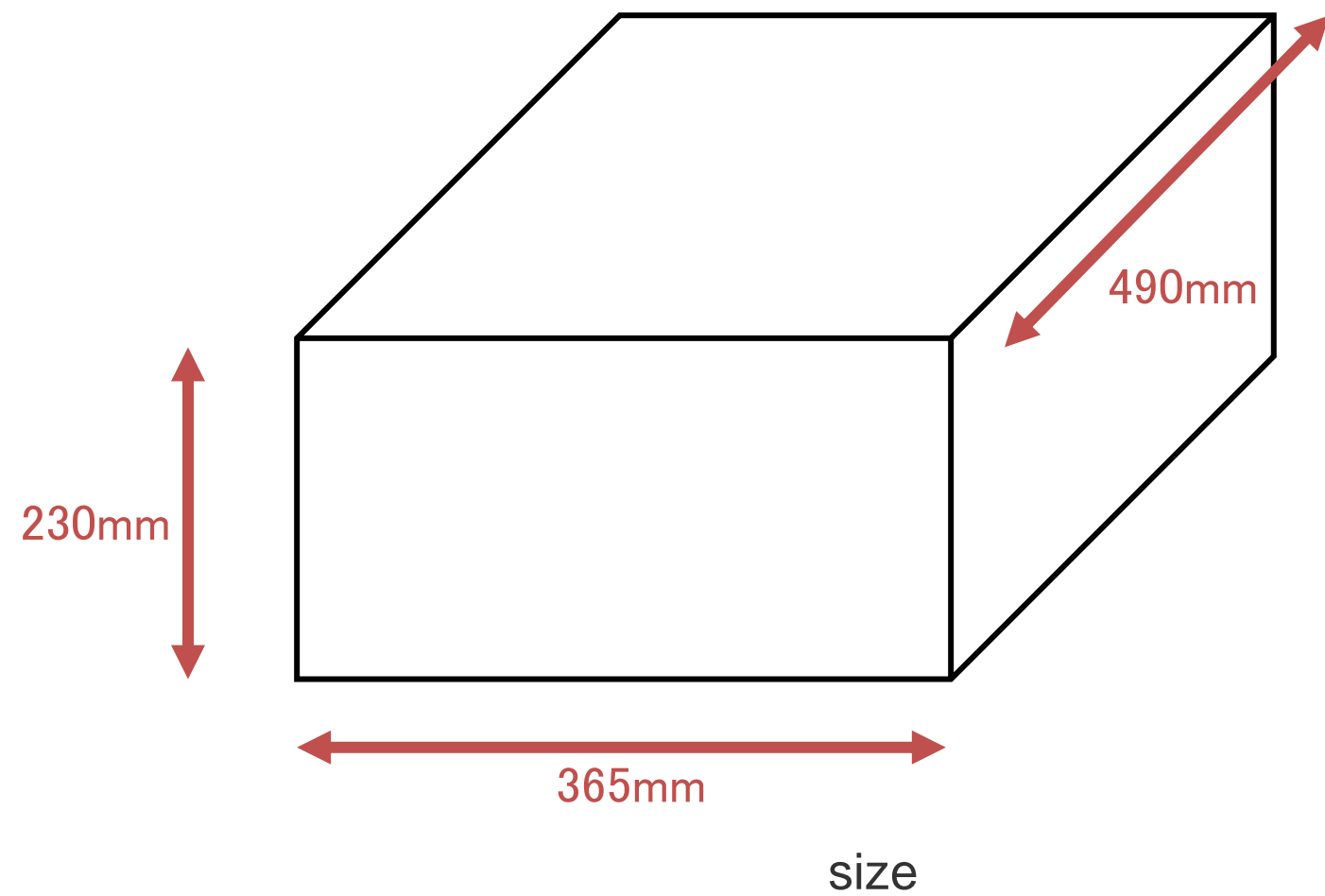

II Product Image ③ Ingredient Specifications

- ① Product name Frozen gilled eel
- ② best if eaten 730 days from date of manufacture (-18° C or less)
by this date 168 time after thawing (below 10° C)
- ③ content by volume Varies depending on size
- ④ Raw material name Eel (cultured in China), soy sauce (some ingredients include soybeans) (manufactured in Japan), mirin-like seasoning, sugar, syrup, galacto-oligosaccharide liquid sugar, yeast extract, /caramel coloring, preservative (sodium benzoate), acidifier (citric acid)

“Acidifier” and “Preservative” are listed as additives, but they are contained in the composite ingredients “Soy sauce” and “Mirin-like seasoning” and are not added during the production of this product.

⑤ Nutrition Facts Label

calorific value	341 kcal
Protein	23.3 g
Lipids	25.3 g
Carbohydrates	5.0 g
Salt Equivalent	0.9 g

(estimated value)

II Manufacturing Engineering



cut up



cleaning



Grill & steam



Grill with sauce



freeze



Weight and metal inspection



bacteriological test



shipping



II examples showing the use



III About Us

Company Name	Fuji Bussan Co.,Ltd
Representative	resident Isako Yamazaki
Incorprated	April 1957
Common Stock	50 million yen
Settlement Type	Once a year in March
Main Business	Sales of petroleum products, sales of petrochemicals, sales of fishery feed, eel farming and processing, sales of frozen foods and marine products, cold storage, operation of gas stations, electricity sales business, sales of solar power generation systems
Location	<p>【head office】 2-5-32,Otsubo, Shimizu-ku, Shizuoka-shi, Shizuoka 424-0847 Japan</p> <p>【Kochi Branch】 770-1 Furukawa, Yoshikawa-cho, Konan-shi, Kochi 781-5242 Japan</p>



FUJI BUSSAN

<https://fuji-bussan.com>

